

# Experimental performance of an absorption diffusion refrigerator

Radhouane Ben Jemaa<sup>#1</sup>, Rami Mansouri<sup>#2</sup>, Ismail Boukhoulda<sup>#3</sup>, Ahmed Bellagi<sup>#4</sup>

<sup>#</sup> U.R. Thermique et Thermodynamique des Procédés Industriels, Ecole Nationale d'Ingenieurs de Monastir, ENIM,  
University of Monastir, Tunisia

<sup>1</sup>[r\\_bjemaa@yahoo.fr](mailto:r_bjemaa@yahoo.fr)

<sup>2</sup>[rami\\_mansouri62@yahoo.fr](mailto:rami_mansouri62@yahoo.fr)

<sup>3</sup>[boukhoulda\\_ismail@yahoo.fr](mailto:boukhoulda_ismail@yahoo.fr)

<sup>4</sup>[ahmed.bellagi@enim.rnu.tn](mailto:ahmed.bellagi@enim.rnu.tn)

**Abstract**— We present in this paper an experimental study of a commercial diffusion-absorption refrigeration machine operating on the Platen and Munters cycle. The temperatures, at the inlet and outlet of every component of the machine, as well as the cabinet and ambient temperature are measured continuously. The tests are repeated for various electric power inputs to the refrigerator. The overall heat transfer coefficient (UA) of the cabinet is determined using both theoretical and experimental methods. This coefficient is found equal to  $0.2W \cdot ^\circ C^{-1}$ . The cooling capacity of the unit and its coefficient of performance are evaluated. These results are analysed and discussed. The necessary heating supplied to the generator of this commercial machine is found between 35W and 45W.

**Keywords**— Refrigeration, diffusion absorption, COP.

## I. INTRODUCTION

Refrigeration is the process of achieving and maintaining a temperature below that of the surroundings, the aim being to cool some product or space to the required temperature. One of the most important applications of refrigeration has been the preservation of perishable food products by storing them at low temperatures. Refrigeration systems are also used extensively for providing thermal comfort to human beings by means of air conditioning [1].

Vapor compression refrigeration systems (refrigerators, air conditioners) are currently most widespread. These machines require electrical or mechanical energy for operating the compressor motor. They also use refrigerants which have proved damaging to the environment.

In addition to the compression-type refrigerators, there are diffusion-absorption refrigerators invented by the two Swedish Balzar Von Platen and Carl Munters [2]. This system uses ammonia as refrigerant, water as absorbent and hydrogen as inert gas. Unlike conventional systems, the total pressure is constant throughout the Platen-Munters system, thus eliminating the need for mechanical pump or compressor. To allow the refrigerant (ammonia) to evaporate at low temperatures in the evaporator, a third inert gas (hydrogen) is introduced.

This system offer several advantages over conventional systems such as [3]:

- High reliability due to absence of moving parts,
- Very little maintenance,
- Silent operation,
- it can be powered by different electricity tensions (AC 220V, AC110V, DC12V, DC24V)
- It can be powered by different thermal energy sources (natural gas, PLG, etc),
- It uses no CFC or HCFC.

Due to the above advantages this system find applications such as refrigerators for remote and rural areas, portable refrigerators, refrigerators for luxury hotel rooms etc.

The coefficient of performance (COP) of this kind of machines is low. To give opportunity for energy savings for products in the growing markets of absorption-type refrigerating appliances, the electric type of these machines were included in the scope of the novel European Union regulation relative to energy labeling of household refrigerating appliances [4].

In this paper we present an experimental and theoretical study of the performance of a commercial diffusion-absorption refrigerator

## II. UNIT DESCRIPTION

The refrigerating machine is a one-compartment refrigerator, of 22 liters capacity (fig.1). It uses ammonia as refrigerant, water as absorbent and hydrogen as inert gas. This machine is powered by the heat generated by electrical resistance. The unit is airtight and constructed of steel. It consists of a generator, a rectifier, a condenser, an evaporator, an absorber and two heat exchangers: a gas exchanger and a solutions heat exchanger (fig.2) [5].

When the heater is turned on, some ammonia-water vapor is driven out of the solution and forms bubbles in the inner pipe of the generator. The bubbles push liquid up in the bubble pump and the vapor passes through the rectifier

where water is removed and returned to the outer pipe. Ammonia-water solution passes through the boiler and the outer pipe of the solution heat exchanger to the liquid inlet of the absorber.

The vapor leaving the rectifier enters the condenser which is a finned pipe with natural convection air cooling. The vapour condenses by rejecting heat to the air and the condensate passes through the gas heat exchanger and flows to evaporator. At the evaporator the ammonia evaporates into the hydrogen. The ammonia-hydrogen mixture leaving the evaporators flows down to the reservoir after passing through the gas heat exchanger and then enters the lower section of the absorber.

In the absorber, the weak solution flows down in counter flow with the ammonia rich hydrogen. The ammonia in the vapor phase is absorbed by the liquid solution. The vapor flows up to the gas heat exchanger, to reach the evaporator. The rich solution leaves the lower section of the absorber, and passes through the inner pipe of the solution heat exchanger to the generator.

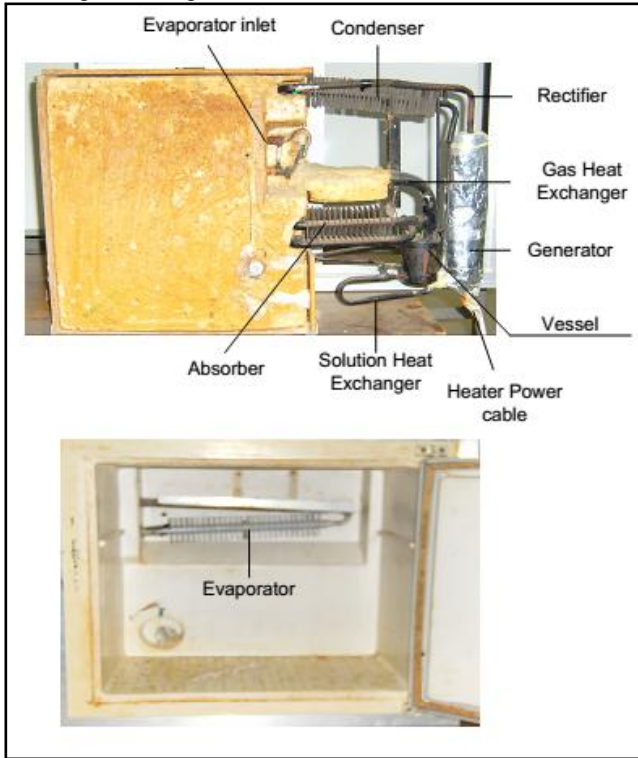

Fig. 1: Refrigerator studied

### III. EXPERIMENTAL SET-UP

The commercial unit is equipped with K-type thermocouples to measure the temperatures at the entrance and exit of each component, the inside of the refrigerator and the ambient temperature (fig 2). An Agilent 34970A data acquisition system was used to collect data from thermocouples. The data were transferred to a computer for analysis and archiving.

The variation of the electric power input to the refrigerator is provided by a controller. For all the tests the

unit is first operated without thermostat which caused the machine to run continuously. After reaching the steady state we set the thermostat on to control the temperature inside the cabinet (Fig. 3).

Fig. 4 displays the evolution of the temperatures for an input power of  $\dot{W}_{elec} = 63W$ . For this power the set-point is  $4^{\circ}C$  and the differential is  $1.5^{\circ}C$ . The shape of this curves shows three operation phases: start-up, steady state and on-off operation.

#### A. COP Determination

The coefficient of performance of the unit is defined as:

$$COP = \frac{\dot{Q}_f}{\dot{W}_{elec}}$$

(1)

$\dot{Q}_f$  is the cooling capacity of the refrigerator and  $\dot{W}_{elec}$  the heat input to the generator.

The cooling capacity can be calculated using the equation

$$\dot{Q}_f = UA (T_{ext} - T_{int})$$

(2)

where  $UA$  is the overall heat transfer coefficient of the refrigerator,  $T_{ext}$  represents the external ambient temperature, and  $T_{int}$  is the food compartment temperature.

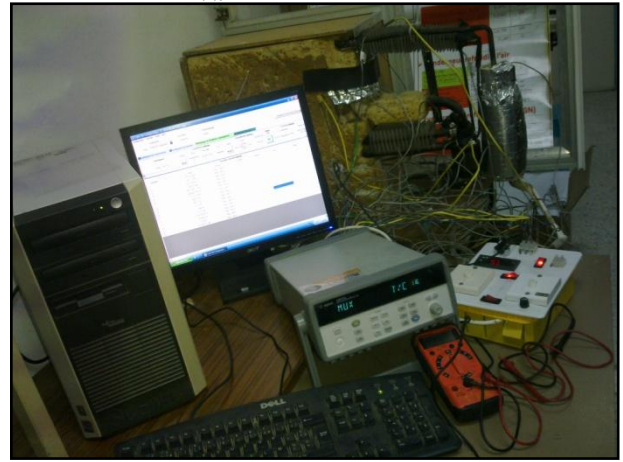

Fig.3: Experimental set up

### IV. DETERMINATION OF THE GLOBAL HEAT TRANSFER COEFFICIENT (UA) OF THE CABINET

To determine the cooling capacity of the unit (eq. 2), it is necessary to find the global heat transfer coefficient of the refrigerator. We propose to determine this coefficient using theoretical and experimental methods.

#### A. Theoretical method

The cabinet of the refrigerator is presented in Fig. 5. The coefficient  $UA$  can be determined using a heat transfer model [6][7].

The cooling capacity of the refrigerator is given by:

$$\dot{Q}_f = UA (T_{ext} - T_{int}) = \dot{Q}_w$$

(3)

Where ( $\dot{Q}_w$ ) is the heat transfer rate from the neighborhood to the cold source through the refrigerator walls (W).

$\dot{Q}_w$  was calculated considering radiation from the neighborhood ( $\dot{Q}_{rad,ext}$ ) and natural convection from the environmental air ( $\dot{Q}_{conv,ext}$ ) to the refrigerator external walls.

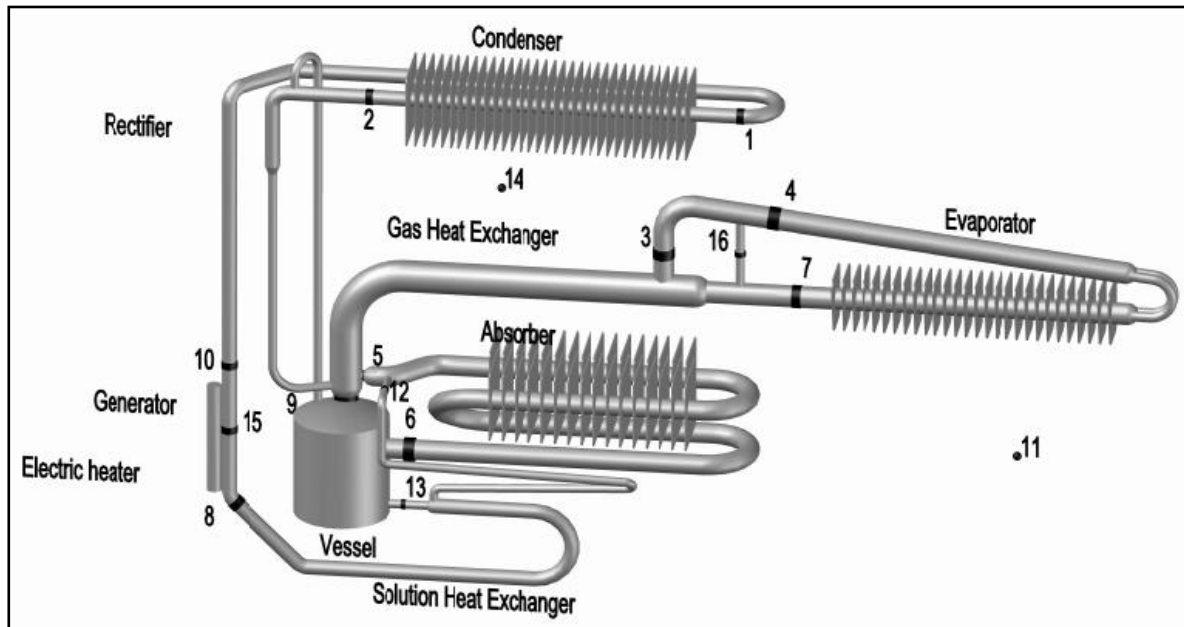

Fig.2 Refrigeration cycle and locations of thermocouples

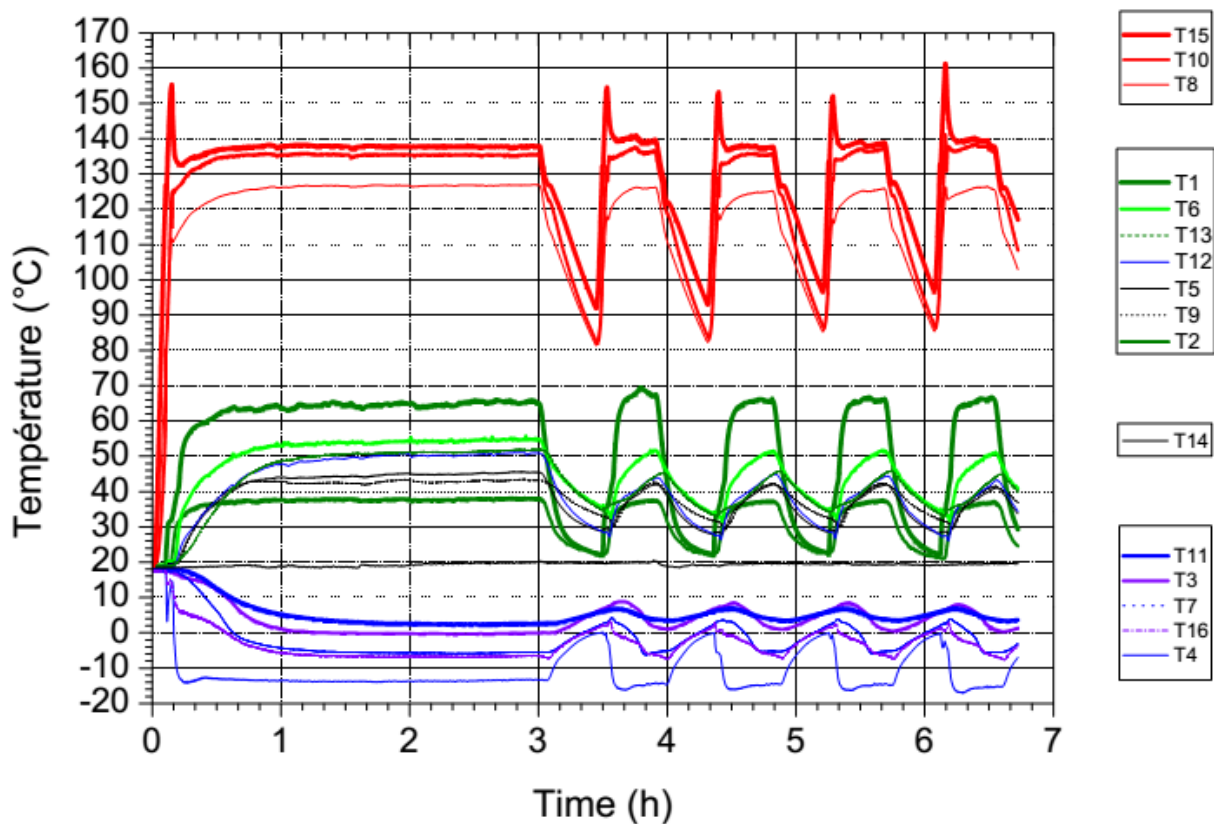

Fig. 4 Evolution of temperatures for  $\dot{W}_{elec} = 63W$

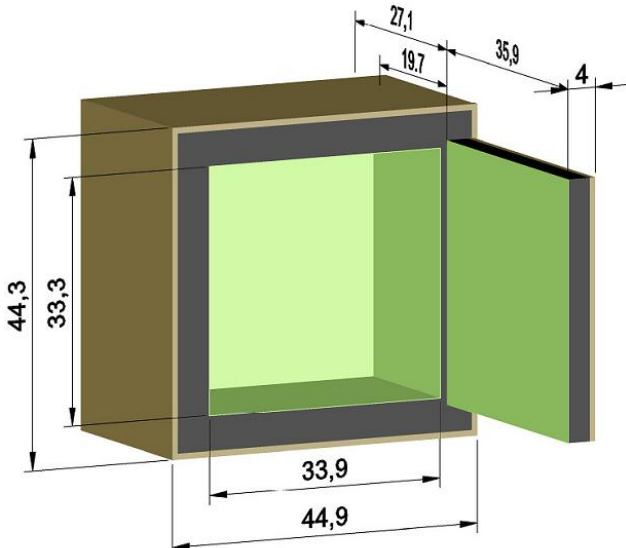

Fig.5 Refrigerator cabinet

This energy was conducted through the refrigerator walls and transferred by natural convection from the refrigerator inner walls to the ambient air inside the refrigerator ( $\dot{Q}_{conv,int}$ ). Thus,

$$\dot{Q}_w = -k_w A_w \frac{T_{sur,int} - T_{sur,ext}}{e_w} = \dot{Q}_{conv,ext} + \dot{Q}_{rad,ext} = \dot{Q}_{conv,int} \quad (4)$$

And

$$\dot{Q}_{conv,ext} = h_{ext} A_{sur,ext} (T_{sur,ext} - T_{ext}) \quad (5)$$

$$\dot{Q}_{rad,ext} = \varepsilon \sigma A_{sur,ext} (T_{neigh}^4 - T_{sur,ext}^4) \quad (6)$$

$$\dot{Q}_{conv,int} = h_{int} A_{sur,int} (T_{sur,int} - T_{int}) \quad (7)$$

Where  $k_w$  is the refrigerator wall thermal conductivity (W/mK),  $A_w$  is the refrigerator wall area frontal to conduction heat flux ( $m^2$ ),  $e_w$  is the refrigerator wall thickness (m),  $h_{ext}$  is the external convection coefficient ( $W/m^2K$ ),  $A_{sur,ext}$  is the refrigerator total external surface area ( $m^2$ ),  $T_{sur,ext}$  is the refrigerator external surface average temperature (K),  $T_{ext}$  is the environmental air temperature (K),  $\varepsilon$  is the refrigerator external surface emissivity,  $\sigma$  is the Stefan-Boltzmann constant ( $5.67 \times 10^{-8} W/m^2K^4$ ),  $T_{neigh}$  is the neighborhood temperature (K), considered to be equal to the environmental air temperature,  $h_{int}$  is the internal convection coefficient ( $W/m^2K$ ),  $A_{sur,int}$  is the refrigerator total internal surface area ( $m^2$ ),  $T_{sur,int}$  is the refrigerator internal surface average temperature (K), and  $T_{int}$  is the ambient air temperature inside the refrigerator (K). The remaining parameters were calculated as shown next.

Heat transferred from the environmental air to the refrigerator external walls and from the refrigerator internal walls to the ambient air inside the refrigerator were calculated considering natural convection to vertical (side surfaces) and horizontal (top and bottom surfaces) plates. For the vertical surfaces the convection coefficients were calculated by:

$$h = \frac{k_f}{L} \left\{ 0.68 + \frac{0.67 Ra_L^{1/4}}{[1 + (0.492/Pr)^9/16]^{4/9}} \right\} \quad (8)$$

For the refrigerator external top surface, the convection coefficient was so evaluated:

$$h = \frac{k_f}{L} 0.27 Ra_L^{1/4} \quad (9)$$

And, for the refrigerator internal top surface, the convection coefficient was thus evaluated:

$$h = \frac{k_f}{L} 0.15 Ra_L^{1/3} \quad (10)$$

Where  $k_f$  is the fluid thermal conductivity (W/m K),  $L$  is the characteristic length of the flat plate (m),  $Ra_L$  is the Rayleigh number, and  $Pr$  is the Prandtl number of the ambient or environmental air.

A program was elaborated, using the software Engineering Equation Solver [8], to solve this set of equations (Eqs. (3)-(10)). The coefficient (UA) is found equal to  $0.1955 W/^\circ C \approx 0.2 W/^\circ C$ .

#### B. Experimental method

To determine the coefficient UA experimentally, the method consists on heating the interior of the cabinet by an electric heater of power  $\dot{W}$  and to measure, when the steady state is reached, the interior and the exterior temperatures  $T_i$  and  $T_e$  [9]. The coefficient global UA is given by:

$$UA = \frac{\dot{W}}{(T_i - T_e)} \quad (4)$$

Where  $\dot{W}$  is the power of the electric heater.

UA is determined by floating  $\dot{W}$  vs.  $(T_i - T_e)$  for various electric heat powers supplied to the resistor (Fig. 6). It is found for our refrigerator:

$$UA = 0.2 W/^\circ C \quad (5)$$

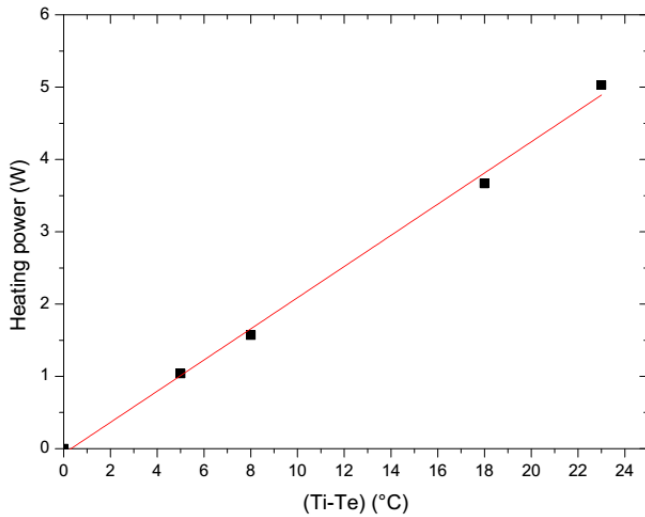

Fig. 6 Heating power vs (Ti-Te)

### V. RESULTS AND DISCUSSIONS

Nine tests with different power inputs to the machine, respectively 14, 18, 26, 34, 41, 47, 56, 63 and 86 W are performed.

Once the global heat transfer coefficient (UA) of the cabinet is determined, the cooling capacity and the coefficient of performance can be calculated. The evolution of the COP vs the generator heat input is presented in Fig. 7. The coefficient of performance decreases when the heat supplied to the generator increases. The COP is upper to 0.1 for heat supplied to the generator lower than 45W.

Fig.8 illustrates the refrigerator temperature attended in the steady state vs the heat input to the generator. This temperature is lower for heating powers under than 50W.

The evolution of the refrigerator temperature for  $\dot{W}_{elec} = 63W$  is presented in Fig. 9. This type of refrigerator is designed for the conservation of foodstuffs. The objective is to stabilize its temperature at 5°C. The necessary time to attend this temperature, for  $\dot{W}_{elec} = 63W$ , is 1 hour. We have determined and represented, for the heat input powers, the electric energy consumed to reach this temperature (fig. 10). This energy has a minimum for  $\dot{W}_{elec}$  between 14 W and 26 W, then increases with the heat supplied to the generator. It is less than 40 Wh for  $\dot{W}_{elec}$  under 45W.

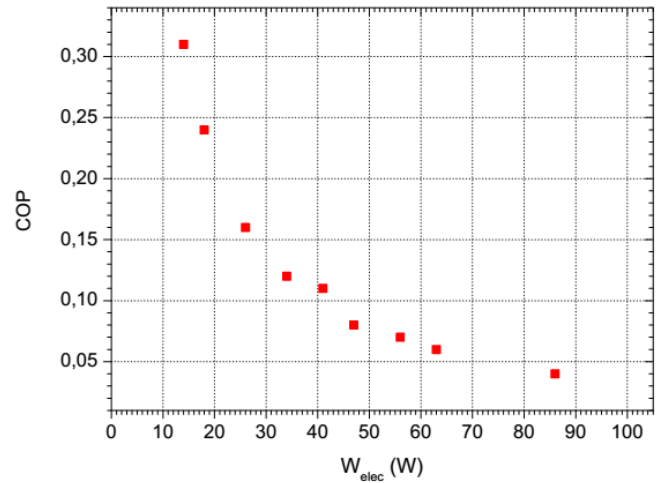

Fig. 7 COP vs generator heat input

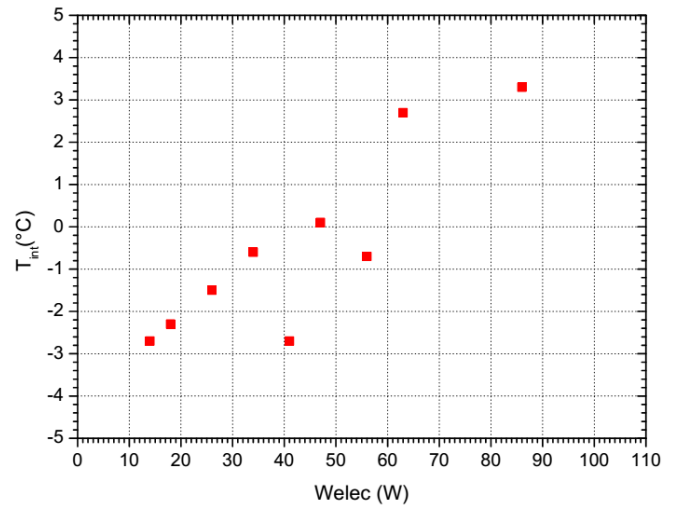

Fig. 8 Interior temperature of the refrigerator vs generator heat input

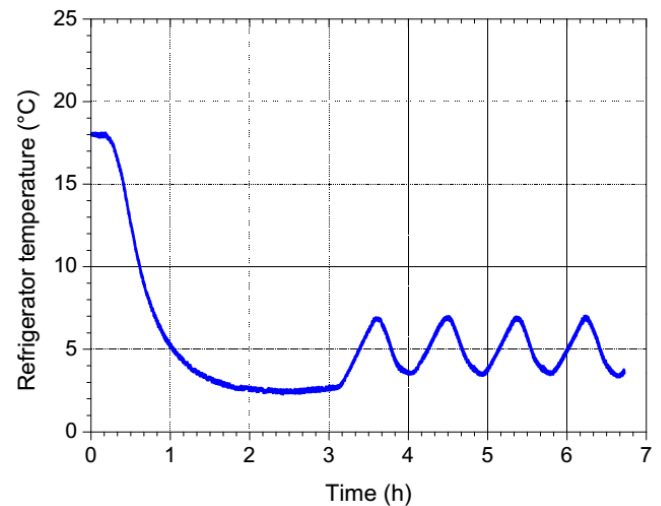

Fig.9 Evolution of the refrigerator temperature for  $\dot{W}_{elec} = 63W$

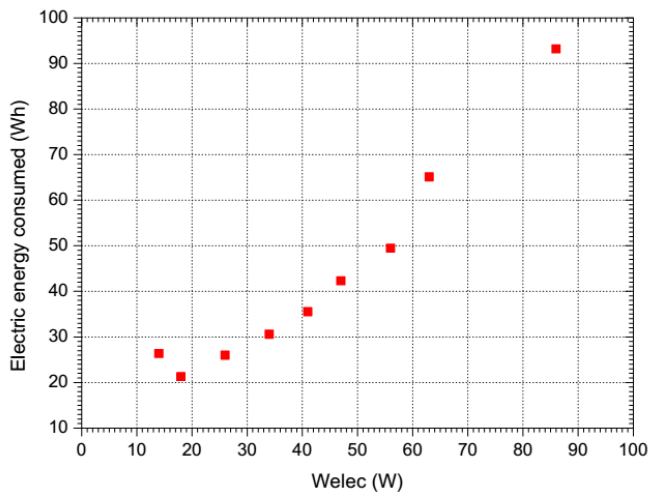

Fig.10 Electric energy consumed vs  $W_{elec}$

According to the previous discussion we found that the heating power required for this machine, used in hotel rooms, is between 35 and 45 W.

## VI. CONCLUSIONS

A Platen-Munters commercial diffusion-absorption refrigerator, used in hotel rooms, is tested under different heat inputs to the generator. The temperature at the inlet and outlet of every component is continuously recorded. The cooling capacity of the refrigerator is calculated after the determination of the global coefficient of heat transfer of the refrigerator. Theoretical and experimental methods are used. In the theoretical method a heat transfer model of the refrigerator cabinet is done, the (UA) found is  $0.2W/^\circ C$ . Experimentally the coefficient (UA) is determined by heating the interior of the refrigerator by electric power supplied to a resistor placed inside the refrigerator, the (UA) is found equal to  $0.2W/^\circ C$ . The variation of the coefficient of performance of the unit and the electric energy consumed for reaching a temperature of  $5^\circ C$ , with the heat supplied to the generator, were analysed. We found that the necessary electric power of the heating element is between 35W and 45W.

## REFERENCES

- [1] Refrigeration and air conditioning, EE IIT, Kharagpur, India, 2008.
- [2] Von Platen, B.C., Munters, C.G., 1928. Refrigerator US Patent 1685764, pp. 685-764.
- [3] R. Ben Jemaa, N. Ben Issa, S. Ben Issa and A. Bellagi, Exergy analysis of a diffusion absorption refrigeration system. International journal of exergy. Vol. 5, Nos. 5/6, (2008).
- [4] Règlement délégué (UE) n°1060/2010 de la commission du 28 septembre 2010, Journal officiel de l'union européenne, L314/17.
- [5] R. Ben Jemaa, R. Mansouri and A. Bellagi, Experimental analysis and thermodynamic modeling of an absorption-diffusion refrigerator. 7<sup>th</sup> International Exergy, Energy and Environment Symposium.
- [6] F. P. Incropera, T.L. Bergman, A. S. Lavine, D. P. Dewitt, Fundamentals of heat and mass transfer, J. Willey.
- [7] A. A. Manzela, S. M. Hanriot, L. C. Gomez, T. R. Sodr , Using engine exhaust gas as energy source for an absorption refrigeration system, Applied Energy, Vol. 87 : 1141-1148, 2010.

- [8] EES - Engineering Equation Solver, Academic Version 6.563, 2003. F-Chart Software. www.fchart.com.
- [9] Chen, J., Kim, K.J., Herold, K.E., 1996. Performance enhancement of a diffusion absorption refrigerator. Int. J. Refrigeration 19(n°3),208-218.